

See discussions, stats, and author profiles for this publication at: <https://www.researchgate.net/publication/303278926>

NUMERICAL PREDICTION OF FRACTURE DURING MANUFACTURING OF THICK WALL TUBES FROM LOW DUCTILITY STEELS IN FLOW FORMING PROCESS

Article · January 2015

READS

12

4 authors, including:



[Andrij Milenin](#)

AGH University of Science and Technology i...

97 PUBLICATIONS 313 CITATIONS

[SEE PROFILE](#)



[Piotr Kustra](#)

AGH University of Science and Technology i...

23 PUBLICATIONS 40 CITATIONS

[SEE PROFILE](#)



[Dorota Joanna Byrska-Wójcik](#)

AGH University of Science and Technology i...

8 PUBLICATIONS 25 CITATIONS

[SEE PROFILE](#)

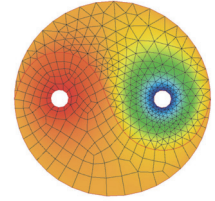

NUMERICAL PREDICTION OF FRACTURE DURING MANUFACTURING OF THICK WALL TUBES FROM LOW DUCTILITY STEELS IN FLOW FORMING PROCESS

ANDRIJ MILENIN, PIOTR KUSTRA, DOROTA BYRSKA-WÓJCIK*, MACIEJ PIETRZYK

AGH University of Science and Technology, al. Mickiewicza 30, 30-059 Kraków

**Corresponding Author: byrska@agh.edu.pl*

Abstract

Process of flow forming has been for a long time used for manufacturing of pipes from low workability alloys. In research on this process special attention was paid to workability (technological plasticity) of the pipe material. In a majority of published research prediction of the workability was made by various fracture criteria, which use stresses and strains calculated by finite element (FE) method. On the other hand, during manufacturing of thick wall tubes cyclic deformation involves repeating of the material loading and unloading. In consequence, residual stresses occur and are accumulated in the tube. These are compressive stresses at the outer surface and tensile stresses at the inner surface. Magnitude of these stresses is comparable with those occurring during deformation. It is expected that using FE program with constitutive laws, which do not account for the unloading phase, may lead to erroneous predictions of conditions of crack appearance as well as of localization of cracks. To prove this thesis two models of the flow forming process for thick wall tubes were developed. Constitutive law in the first model accounted for both elastic-plastic deformation and elastic unloading. The second simplified model used the rigid-plastic flow rule. The material flow stress model was the same in both solutions, with initial part representing elastic deformation. The models were implemented in the Qform8 software. Obtained results show that in the first case large tensile stresses at the inner surface were predicted, what means an increased risk of fracture. These stresses occur not only in the deformation zone but also along the tube. In the second solution, which did not account for the unloading, maximum stresses occur directly in the deformation zone. Distribution of the fracture criterion parameters shows differences in the localization of fracture for these two solutions. The first variant predicted fracture at the inner surface of the tube, while the second variant at the outer surface. The former was confirmed by experimental results. Necessity of accounting for unloading cycle in simulations of the flow forming for thick tubes was confirmed.

Key words: secondary metallurgy, ladle nozzle opening, modeling

1. INTRODUCTION

Process of flow forming has been for a long time used for manufacturing of pipes from alloys characterized by a low workability. A detailed review of the history of this process and the basic principles of its design can be found in (Wong et al., 2003; Kuss & Buchmayr, 2014). In modelling flow forming special attention is given to spinnability (technological plasticity) of the pipe material. Currently various modifications of flow forming processes have been developed (Mohebbi & Akbarzadeh, 2010; Hua et al., 2005; Depriester & Massoni, 2014). Numerical

modeling supports the design of new processes and it allows to decrease the number of industrial trials.

All known models of flow forming process use commercial finite element (FE) software. The paper (Hua et al., 2005) considers the process of deformation of the pipe in the machine with three rollers. Rollers are installed at the same position along the pipe. ANSYS software was used for numerical calculations. The authors managed to obtain a qualitative match shape of a longitudinal section of the pipe in calculations and in experiments. However, a very coarse FE grid was used in that paper and it did not allow to make a prediction of fracture. Program

ABAQUS was used for simulation of the flow forming in the machine with one roller in the paper (Mohebbi & Akbarzadeh, 2010). Authors managed to obtain a qualitative match of the character of the metal flow in the deformation zone on the coarse grid. A similar result was obtained by Kuss and Buchmayr (2014) by using SIMUFACT FE program. The reverse deformation of thin-walled tubes made from titanium alloy Ti-6Al-4V in two roller machine was considered by Depriester and Massoni (2014). Authors used the program FORGE. The aim of that work was the prognosis of fracture. Several failure criteria were implemented in the commercial version of FORGE and used to predict failure. Results of calculation were compared with experimental data. In the experiment, longitudinal cracks were observed, the prediction of which was carried out using three fracture criteria: Cockcroft-Latham, Rice-Tracey and Oyane.

The process investigated in the present paper concerns thick wall tubes. In this process the deformation is carried out by three rollers and transverse cracks appear at the inner surface of the tubes. Due to this, the following new factors influencing the flow forming process have to be considered:

1. During the deformation of thick-wall tubes significantly inhomogeneous deformation occurs. Under these conditions, alternating loading and unloading leads to residual stresses, which cannot be neglected in the analysis of the process.
2. Alternating stages of loading and unloading lead to a large number of load cycles, which involve significant tensile residual stresses at the inner surface of the tube. Due to this, the process of failure has to be considered from the perspective of the theory of low-cycle loading.

This paper discusses the numerical model of the reverse flow forming of the pipe made from Inconel 718 alloy using three roller machine. Additionally, two models of rigid-viscoplastic theory of deformation and the elastic-plastic theory are compared. The analysis of the applicability of these two types of fracture theories, based on critical deformation and low-cycle fracture theory, is shown.

2. DESCRIPTION OF THE PROCESS

Analysis of the available publications led to a conclusion that problem of the material workability during flow forming is extremely important and it is still not solved. Therefore, the present work is focused on simulations of this process and evaluation

of the tendency to material fracture. The scheme of the reverse flow forming process is shown in figure 1.

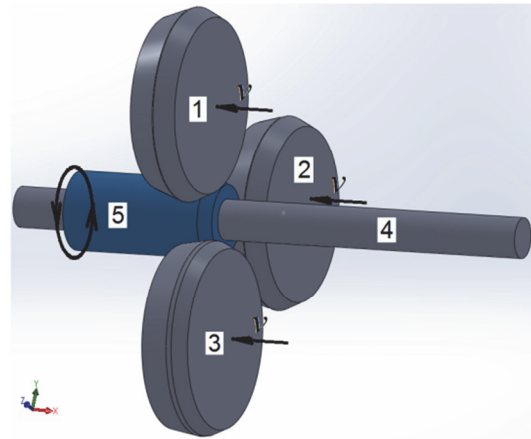

Fig. 1. Scheme of the reverse flow forming process (1, 2, 3 - rollers, 4 - mandrel and 5 - tube) using three rollers machine.

Rollers can be set at different position along the pipe. The deformation is carried out by each of the rollers and it is adjusted by changing the distance from the roller axis and centerline of the tube. Thus, in this process a large number of factors influences the stress-strain state of the material and consequently, its technological plasticity. The main factors are:

- attack angle of rollers (α),
- feed rate, mm/rpm (FR),
- the strain distribution between rollers.

The character of the impact of some of these factors is described in (Wong et al., 2003; Kuss & Buchmayr, 2014). The following relations between factors of flow forming process and process parameters are known:

1. The influence of the feed rate on process parameters. Reduction of the feed rate leads to an increase of the internal diameter of the pipe. An increase of the feed rate causes an increase of different types of surface defects, increase of the force and deterioration of dimensional accuracy of the pipe.
2. The influence of the attack angle on process parameters. With the increase of the attack angle the axial flow is increased and radial flow of the material is reduced. Beyond this the number of different types of surface defects increases as well as longitudinal force on the rollers. An increase of the attack angle reduces the internal diameter of the pipe.
3. Feed rate is the only parameter, which significantly influences on spinnability. Increase of FR reduces spinnability.



4. Two types of defects may occur during flow forming:

- The first type are long and sharp longitudinal wall cracks. These cracks have been attributed to inclusions in the material, resulting in large stress concentrations around those particles.
- The second type are internal circular cracks, occurring at the inner surface of the tube. These cracks are similar to the well-known central burst defect (also called chevron defect), reported in tube and rod drawing (Avitzur, 1968). Example of this type of defect is shown in figure 2. In the present paper an attempt was made to simulate internal circular cracks based on the following assumptions.

5. A significant role is played by the residual stresses induced in the inner surface of the tube during processing.

6. To apply the theory of the process low-cycle of destruction.

To test these assumptions, a comparative calculations using the rigid plastic theory and the theory of elastic plastic deformation have been performed. Two fundamentally different models of failure have also been developed. One is based on the ultimate strain theory, the other based on the low-cycle theory of failure.

analysis: 20, 100, 200, 300 and 400°C. The axisymmetrical compression tests were performed on GLEEBLE thermophysical simulator for following strain rates 0.1, 1, 10s⁻¹. Tested material was Inconel 718 alloy and the dimensions of the samples were $\phi 7 \times 9$ mm. The procedure was composed of the following steps:

- heating to the test temperature with the rate of 3°C/s,
- maintaining at the test temperature for 120 s,
- compression,
- cooling in air.

Results of load measurements for all tests are presented in figure 3. These data were used as input for the inverse analysis to obtain flow stress of tested material. Dependence of the loads registered during experiments for given strain rate on the temperature is negligible.

The inverse analysis for the compression data was performed using the algorithm described by Szeliga et al. (2006) and the results are presented in figure 4. Due to principles of the inverse analysis and assumptions of the boundary conditions described above, the obtained can be considered as real material properties at the isothermal conditions and constant strain rate.

The flow curves obtained from the inverse analysis were approximated using the Hensel-Spittel

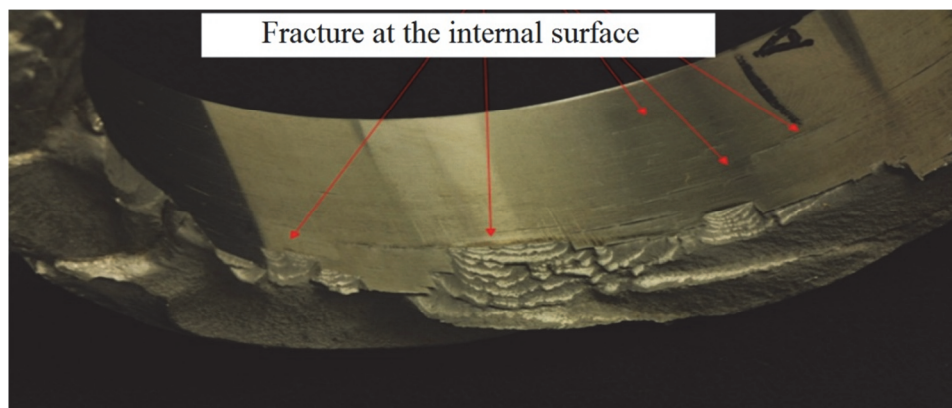

Fig. 2. Cracks at the inner surface of the pipe in the experiment.

3. IDENTIFICATION OF THE MATERIAL MODEL

3.1. Flow stress model

Preliminary calculations have shown that in the flow forming process the temperature in the deformation zone can increase up to 400°C. For this reason, the following temperatures were selected for the

equation (Hensel & Spittel, 1979):

$$\sigma_p = A \varepsilon^n \exp(-q\varepsilon) \dot{\varepsilon}^m \exp(-\beta t) \quad (1)$$

where: σ_p – flow stress, ε – strain, $\dot{\varepsilon}$ – strain rate, t – temperature in °C, A, q, β, m, n – coefficients. The coefficients in the model, which were determined on the basis of the data obtained from the inverse analysis, are given in table 1. The final value of the objective function ϕ , which is the measure of the accuracy



of the inverse solution, is given in the last column of this table. Thus, the flow stress insensitive to the effect of friction, deformation heating and sample dimensions in the tests was determined to the strain of about 1 for the Inconel 718.

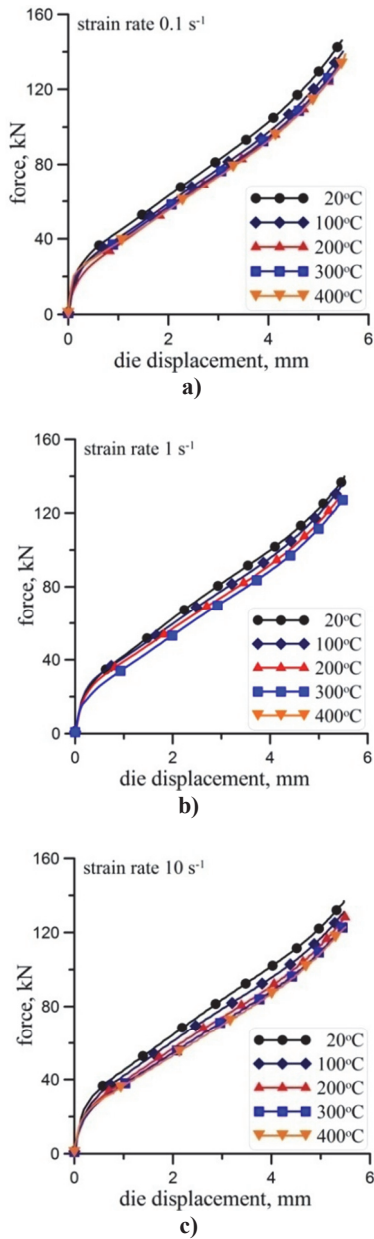

Fig. 3. Loads recorded during tests for Inconel 718 alloy for strain rate $0.1s^{-1}$, $1s^{-1}$ and $10s^{-1}$ and temperature range from 20 to $400^{\circ}C$.

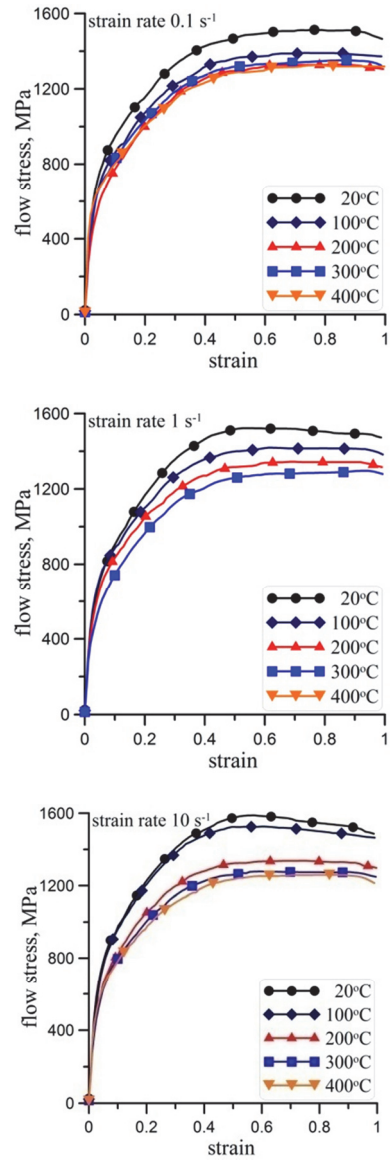

Fig. 4. Flow stress determined by the inverse analysis as function of strain for strain rate $0.1s^{-1}$, $1s^{-1}$ and $10s^{-1}$ and for temperature range from 20 to $400^{\circ}C$.

3.2. Elastic- plastic properties

Two models of flow forming process were considered in present paper. The first model assumes the rigid-viscoplastic theory of deformation and the second includes the elastic-plastic theory. Figures 5 and 6 present experimental values of Young modulus and yield stress respectively depending on the temperature for the Inconel 718 alloy.

Table 1. Coefficients of Hensel-Spittel equation (1) determined using the inverse analysis.

Material	A	n	q	m	β	ϕ
Inconel 718	2745.6	0.4417	0.6108	0.00055	0.000464	0.0501



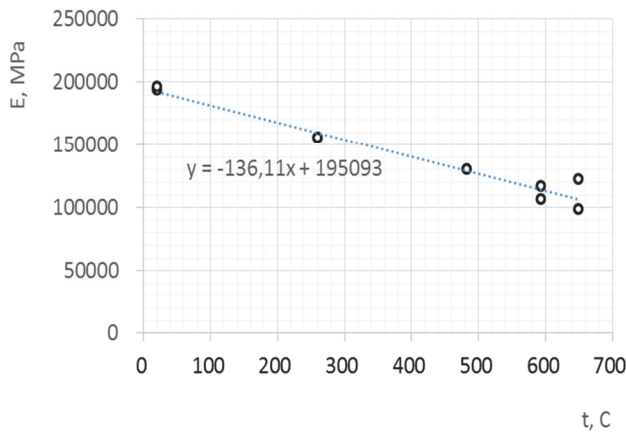

Fig. 5. Young modulus dependence on the temperature for the Inconel 718 alloy.

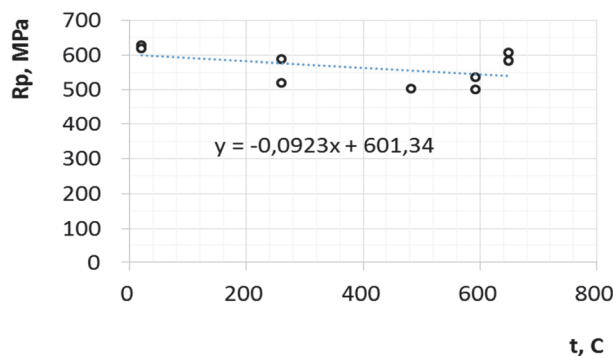

Fig. 6. Yield stress dependence on the temperature for the Inconel 718 alloy.

4. FLOW RULES USED IN SIMULATIONS

During manufacturing of thick wall tubes cyclic deformation involves repeating of the loading and unloading of the material. In consequence residual stresses occur and are accumulated in the tube. These are compressive stresses at the outer surface and tensile stresses at the inner surface. Magnitude of these stresses is comparable with those occurring during deformation. It is expected that using FE programs with constitutive laws, which do not account for the unloading phase, may lead to erroneous predictions not only of conditions of crack appearance but also of localization of cracks. To prove this thesis, two models of the flow forming process for thick wall tubes were developed. The first model used rigid-plastic flow rule. Constitutive law in the second model accounted for both elastic-plastic material deformation and elastic unloading. The material flow stress model was the same in both solutions, with initial part representing elastic deformation. In the paper two flow rules, implemented in Qform

program (Stebunov et al., 2011; Biba et al., 2015), were considered. The first model of flow forming, considered in the paper, is based on the theory of rigid-viscoplastic deformation. The system of governing equation includes: equilibrium equations:

$$\sigma_{ij,i} = 0, \tag{2}$$

compatibility condition:

$$\dot{\epsilon}_{ij} = \frac{1}{2}(v_{i,j} + v_{j,i}), \tag{3}$$

constitutive equations:

$$\sigma'_{ij} = \frac{2\bar{\sigma}}{3\dot{\epsilon}^p} \dot{\epsilon}_{ij}, \tag{4}$$

incompressibility equation:

$$v_{i,j} = 0 \tag{5}$$

energy balance equation:

$$\rho c \dot{t} = k (t_{,i})_{,i} + \beta \bar{\sigma} \dot{\epsilon}^p \tag{6}$$

and expression for flow stress (1), where: σ_{ij} – stress tensor, $\dot{\epsilon}_{ij}$ – strain rate tensor, $\dot{\epsilon}^p$ – effective strain rate for plastic deformation, v_i – velocity component, σ'_{ij} – deviator stress tensor, $\bar{\sigma}$ – effective stress, which according to the Huber-Mises yield criterion is equal to the flow stress calculated from equation (1), t – temperature, β – heat generation efficiency, which is usually assumed as $\beta = 0.9 - 9.95$, ρ – density, c – specific heat, k – thermal conductivity.

In equations (2)-(6) summation convention is used. Equations (2)-(5) were transformed into discrete form by means of virtual work-rate principle and finite element technique what resulted in the non-linear system of algebraic equations, where nodal values of velocity components and mean stress are considered as independent variables.

For comparison purpose the second model was tested, in which the elastic-plastic constitutive law was used. According to the Prandtl-Reuss theory, implemented in QForm software, strain is decomposed into an elastic and a plastic part. The constitutive law takes the form:

$$\dot{\epsilon}'_{ij} = \frac{\dot{\sigma}'_{ij}}{2G} + \frac{3}{2} \frac{\dot{\epsilon}^p}{\bar{\sigma}} \sigma'_{ij} \tag{7}$$



where: σ'_{ij} - the deviator stress tensor, $\dot{\epsilon}'_{ij}$ - the deviator strain rate tensor, G is the shear modulus.

The strain rate depends on the deviatoric stress and its rate. The first term in equation (7) is related to the elastic deformation and the second to plastic part of deformation (Stebunov et al., 2011).

In QForm software the derivative of the mean stress is calculated by the finite difference over a small time interval $\Delta\tau$:

$$\dot{\sigma} = \frac{d\sigma}{d\tau} \approx \frac{1}{\Delta\tau} (\sigma - \tilde{\sigma}) \quad (8)$$

where the sign $\tilde{\cdot}$ is used to denote the value of the function in previous time step and implicit integration is supposed to be used (Stebunov et al., 2011).

Thus, the elastic-plastic model can be expressed by equation:

$$\sigma'_{ij} = 2G^p \Delta\tau \dot{\epsilon}'_{ij} + \frac{G^p}{G} \tilde{\sigma}'_{ij} \quad (9)$$

where

$$\frac{1}{G^p} = \frac{1}{G} + \frac{3\dot{\epsilon}^p \Delta\tau}{\bar{\sigma}} \quad (10)$$

Equation (9) should include the relation between the increments of volumetric strain and the mean stress:

$$\sigma_0 = K\Delta\tau \dot{\epsilon}_V + \tilde{\sigma}_0 \quad (11)$$

where: K - bulk elastic modulus, σ_0 - mean stress, $\dot{\epsilon}_V$ - volumetric strain rate.

In this model an algorithm of unloading and occurrence of residual stress was implemented.

5. ANALYSIS OF THE INFLUENCE OF THE APPLIED FLOW RULE

Figures 7 and 8 show comparison of results obtained from the two solutions described in the previous section. In the rigid-viscoplastic solution, which did not account for the unloading, maximum stresses occur directly in the deformation zone (figures 7a and 8a). In the elastic-plastic solution the large tensile stresses at the inner surface were predicted (figure 8b), what means an increased risk of fracture. These stresses occur not only in the deformation zone but also along the tube. In both models the maximum value of stress appears in the contact area of roller with material, but in elastic-plastic model the residual stresses still stay in material after de-

formation (figure 7b). Similar results were obtained in the work (Biba et al., 2015).

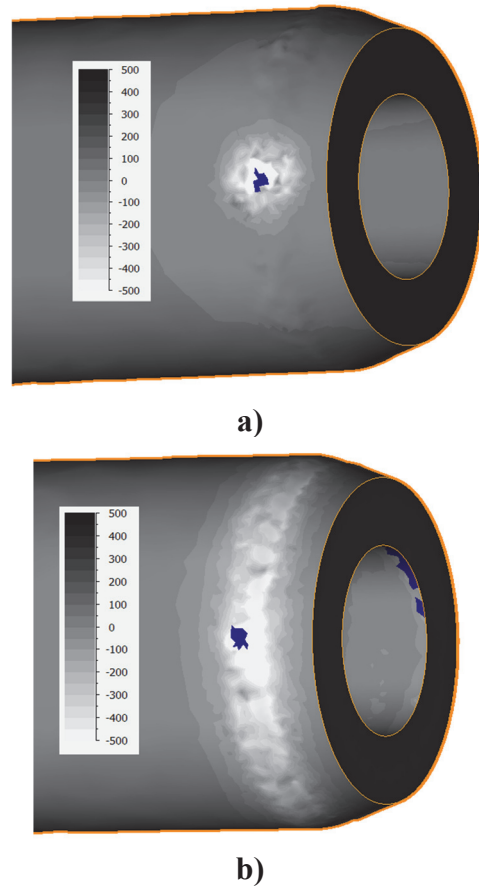

Fig. 7. The distribution of mean stress during initial stage of flow forming process.

Figure 8 shows results of simulation of flow forming process for later stage of deformation. In simulations using the elastic-plastic constitutive law the residual tensile stresses were obtained at the inner surface of the tube what could explain the fracture of tube in this area. Application of the rigid-viscoplastic theory leads not only to errors in calculations of stresses but also to wrong sign of these stresses. The stress at inner surface of tube should be tensile, what is of significant meaning to proper predictions of the fracture of the tube.

In figure 8 the distribution of the triaxiality factor k is presented ($k = \sigma_0 / \bar{\sigma}$). Results for the rigid-viscoplastic model are shown on the left and results for the elastic-plastic model are depicted on the right. It can be seen that these two models give not only different values of stresses but also stress state is completely different. It particularly concerns the inner surface of the pipe. Significant tensile residual stresses were predicted by the calculations based on the elastic-plastic model. The magnitude of these stresses approaches the value of the yield stress ($k = 0.8$). This level of residual stresses may fundamen-



tally influence the forecast of the destruction. This conclusion is important because in experiment the cracks are observed at the inner surface of tube.

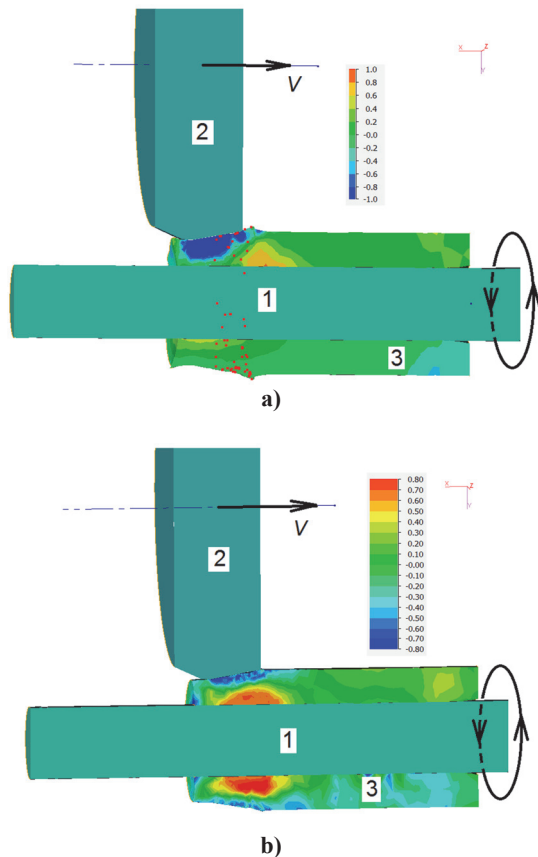

Fig. 8. Scheme of the reverse flow forming process (1 –mandrel, 2 – roller, 3- tube) and distribution of the triaxiality factor using rigid-plastic (a) and elastic-plastic (b) constitutive law in the longitudinal section of tube.

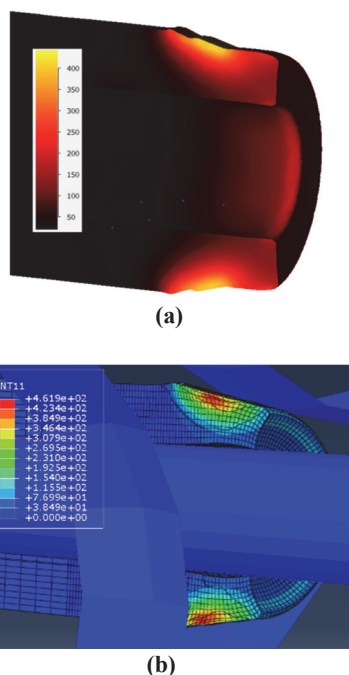

Fig. 9. Distribution of temperature for elastic-plastic model calculated by (a) Qform, (b) ABAQUS.

The temperature during process can reach values of about 450°C, what is shown in figure 9. Calculations of the temperature have also been made in ABAQUS software and similar results were obtained. The increase of the temperature additionally causes higher values of compressive stresses in the area of contact of the tube with the tools. In this case the values of tensile stresses at the inner surface increase, as well.

6. CYCLIC LOAD IMPACT

In the flow forming process of thick tubes the tube is deformed by rollers many times, thus the cyclicality of deformation process could be important in terms of the fracture prediction. Therefore, the next step of the analysis composed study of impact of cyclic load on stress-strain state in the material during the process. The analysis of fracture during low cyclic loading of Inconel 718 in wide range of temperature was done in work (Laflen & Cook, 1982). The stress-strain analysis is necessary for using a low cycle theory of fracture. The calculated dependence of the mean stress at the inner surface on time during flow forming process is shown in figures 10 and 11. Figure 10 presents results of simulations using elastic-plastic constitutive law and figure 11 using rigid-viscoplastic law. In rigid-viscoplastic model values of mean stress are oscillating around value 0, whilst in elastic-plastic model values of mean stress are increasing with increasing number of cycles of deformation. This is an effect of tensile residual stresses at the inner surface of tube. The peaks visible in both figures are related with deformation of the tube in moment of contact with roller.

7. SELECTION OF THE FRACTURE CRITERIA

Selection of an appropriate fracture criterion is crucial for accurate prediction of the fracture in flow forming process. Two fracture models were tested in this paper. The first is the Kolmogorov criterion (Kolmogorov, 1986) based on the value of critical strain $\bar{\epsilon}_c$. Fracture parameter D is given by equation:

$$D = \frac{\bar{\epsilon}}{\bar{\epsilon}_c(t, k)}, \tag{12}$$

where: t – temperature, k - triaxiality factor.

In the model of flow forming the value of D is calculated by integration (summation) of strain over all steps of simulation:



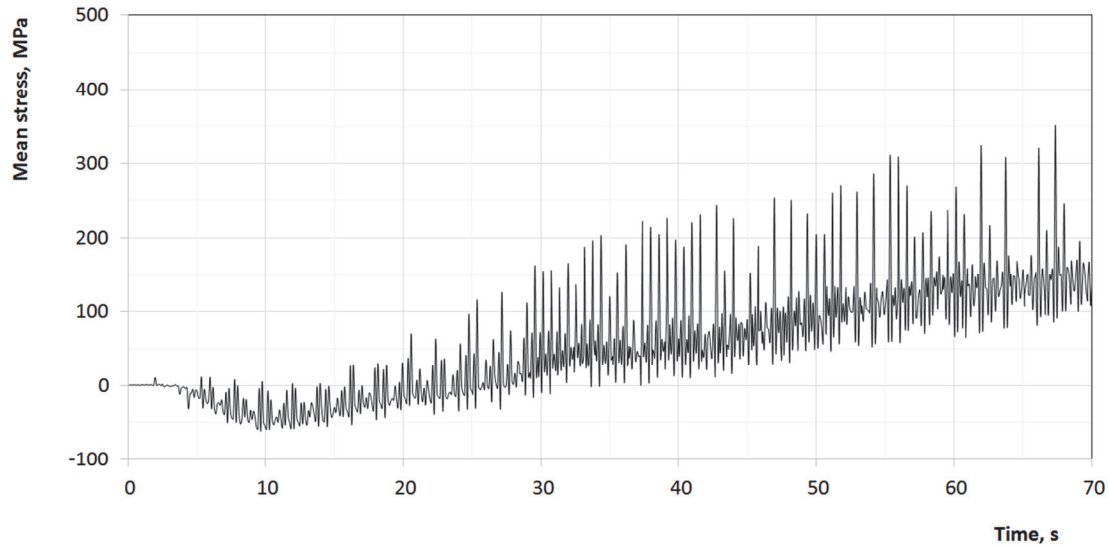

Fig. 10. Values of mean stresses at selected point for elastic-plastic model of flow-forming.

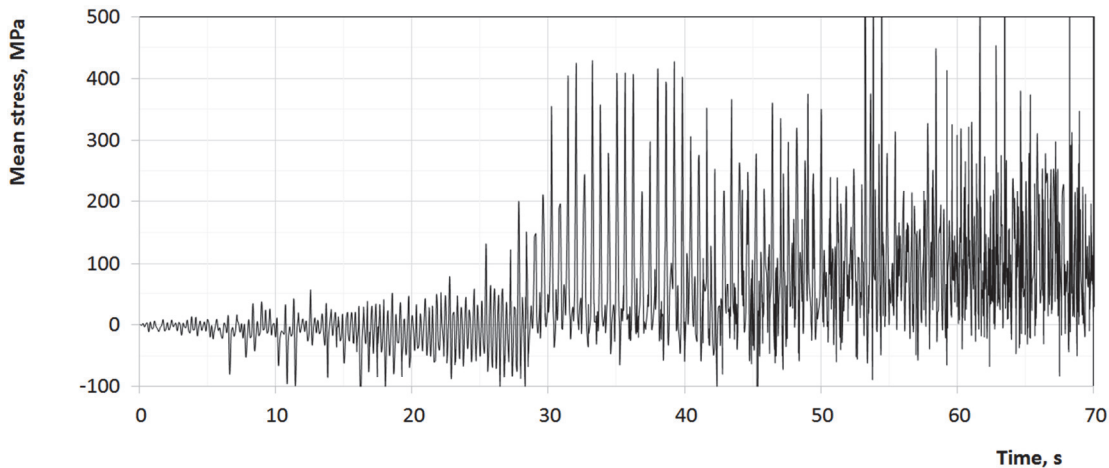

Fig. 11. Values of mean stresses at selected point for rigid-viscoplastic model of flow-forming.

$$D = \int_0^{\bar{\varepsilon}} \frac{d\bar{\varepsilon}}{\bar{\varepsilon}_c(t, k)} \approx \sum_{i=1}^n \frac{\Delta \bar{\varepsilon}_i}{\bar{\varepsilon}_c(t, k_i)}, \quad (13)$$

where: n - number of strain increments during numerical integration.

For calibration of critical strain model the tensile tests were performed for temperature range 20-650 C (figure 12). These results show that reduction of area of the sample does not depend on the temperature. An average reduction of area was 55% for temperature range 20-600°C.

The value of critical strain depending on triaxility factor for Inconel 718 was obtained through rescaling data for pure nickel for $k=1$. Figure 13 presents values of this critical strain compared with the data for pure nickel (Kolmogorov, 1986). Since the dependence of the critical strain on temperature is negligible, the fracture criterion (13) does not depend on temperature either.

The second model of fracture considered in the paper is a model, which depends on a number of deformation cycles in the process. The number of cycles to fracture initiation depending on equivalent strain in one cycle was obtained by [Laflen and Cook \(1982\)](#) for temperature range 20-570°C and was not sensitive to the temperature for Inconel 718 alloy. Statistical analysis of this data shows that good approximation can be obtained by using the following function:

$$N_i(\varepsilon_{eq}) = 657.07 \varepsilon_{eq}^{-6.997} \quad (14)$$

where: ε_{eq} - equivalent strain, $N_i(\varepsilon_{eq})$ - the number of cycles to initiation of a crack for the current cycle number i . The equivalent strain in % is calculated from the equation proposed by [Laflen and Cook \(1982\)](#):



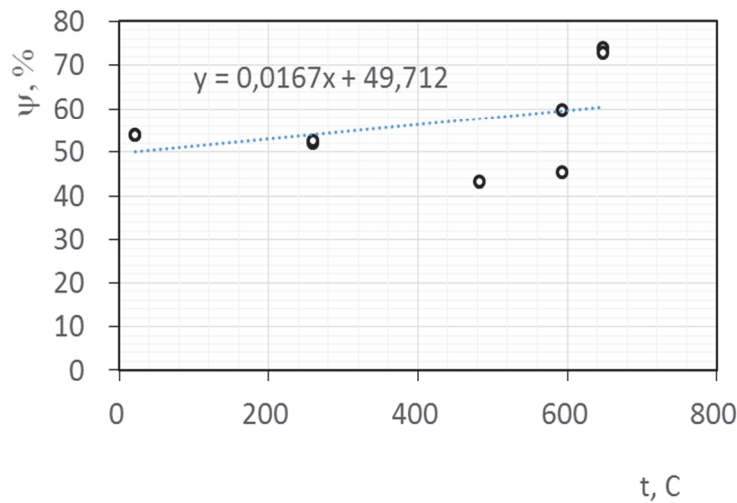

Fig. 12. The percentage reduction in area of the sample made of the Inconel 718 alloy.

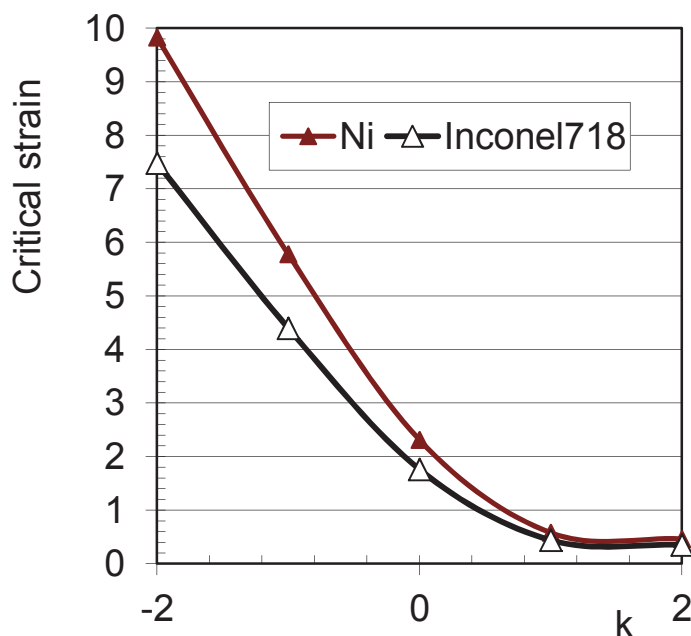

Fig. 13. Critical strain depending on triaxiality factor for pure nickel and Inconel 718 alloy.

$$\varepsilon_{eq} = \left(\frac{\sigma_{max}}{E(t)} \right)^{1-m} \Delta\varepsilon^m, \quad (15)$$

where: $\Delta\varepsilon$ – strain increment during one cycle of deformation per roller (in %), σ_{max} – maximum mean stress during cycle, $E(t)$ – Young modulus, m – an arbitrary correlation parameter, according (Lafien & Cook, 1982) $m = 0.7$.

Based on this data the following fracture criterion was proposed:

$$D = \sum_{i=1}^n \frac{1}{N_i(\varepsilon_{eq})}, \quad (16)$$

where i – number of current cycle, n – total number of cycles for current point of the tube.

8. IMPLEMENTATION OF FRACTURE CRITERIA INTO QFORM PROGRAM AND ANALYSIS OF RESULTS

Described models of fracture were implemented into Qform software as user-defined subroutines using specialized language Lua (Ierusalimschy, 2013). Figures 14 and 15 show implementation of the Kolmogorov fracture criterion (13) in the Qform. Results of simulation of the flow forming process using this criterion (13) are shown in figure 14. The maximum values of fracture parameter are located at the outer surface of the tube, what does not coincide with the experimental data (in experiment fracture is initiated at the inner surface of tube).

Results of simulation of the process using fracture criterion (16), which takes into account the cyclicity of the process, are shown in figure 16. Figures 16a-16c present distribution of this criterion. Figure 16d shows results for Kolmogorov fracture criteria for comparison purposes. It is seen that fracture criterion based on equation (16) works better and it predicts the localization of fracture initiation correctly (inner surface of the tube). Beyond this, the values of the fracture criterion are close to the critical value of 1.0 for conditions of flow forming, where fracture was observed in experiments.



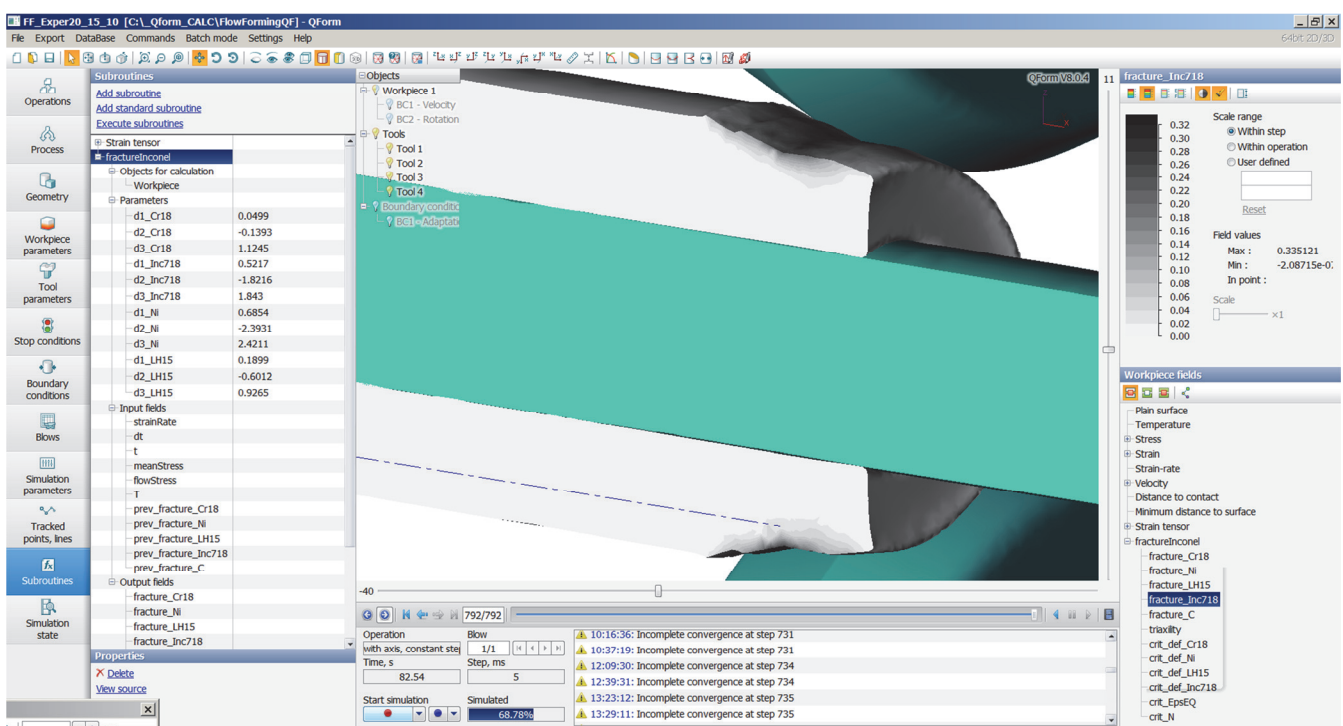

Fig. 14. Screenshot from simulation of the flow forming process with fracture criteria distribution based on the critical strain.

```

set_target_workpiece()

d1_Inc718 = parameter ("d1_Inc718", 0.5217)
d2_Inc718 = parameter ("d2_Inc718",-1.8216)
d3_Inc718 = parameter ("d3_Inc718", 1.843)
fracture_Inc718 = result("fracture_Inc718", 0)
triaxility = result("triaxility", 0)
crit_def_Inc718 = result("crit_def_Inc718", 0)

function UserFields( strainRate, dt, meanStress, flowStress, T,
prev_fracture_Cr18, prev_fracture_Ni, prev_fracture_LH15,
prev_fracture_Inc718 )

    local s0 = meanStress/1000000
    local Ss = flowStress/1000000
    local ktr = s0/Ss
    store(triaxility, ktr)

    local defP_Inc718 = d1_Inc718*ktr^2 + d2_Inc718*ktr +
d3_Inc718;
    dPsi = dt*strainRate / defP_Inc718
    Psi = prev_fracture_Inc718 + dPsi
    store(fracture_Inc718, Psi)
    store(crit_def_Inc718, defP_Inc718)
end

```

Fig. 15. Fragment of Lua code showing the implementation of Kolmogorov (13) fracture criteria in Qform software.

6. CONCLUSION

1. Phenomenon of occurrence of residual stress cannot be neglected in simulations of the flow forming of thick-walled pipes. Tensile residual stresses at the inner surface of the pipe are the result of an alternative occurrence of the active deformation and unloading rollers. The value of tensile residual stress at the inner tube surface is comparable to the yield stress. For this reason, they can significantly affect the fracture.

- Application of the rigid-plastic theory of plasticity does not allow to simulate the effect of unloading and the occurrence of residual stress. For this reason, this approach is not suitable for simulation of the flow forming of thick-walled tubes.
- A large number of deformation cycles allows to consider the flow forming from the viewpoint of low-cycle theory of fracture. This approach allows to predict correctly the localization of fracture. Commonly used failure criteria based on the critical strain give wrong prediction of the localization of the failure in the flow forming of thick-walled tubes.



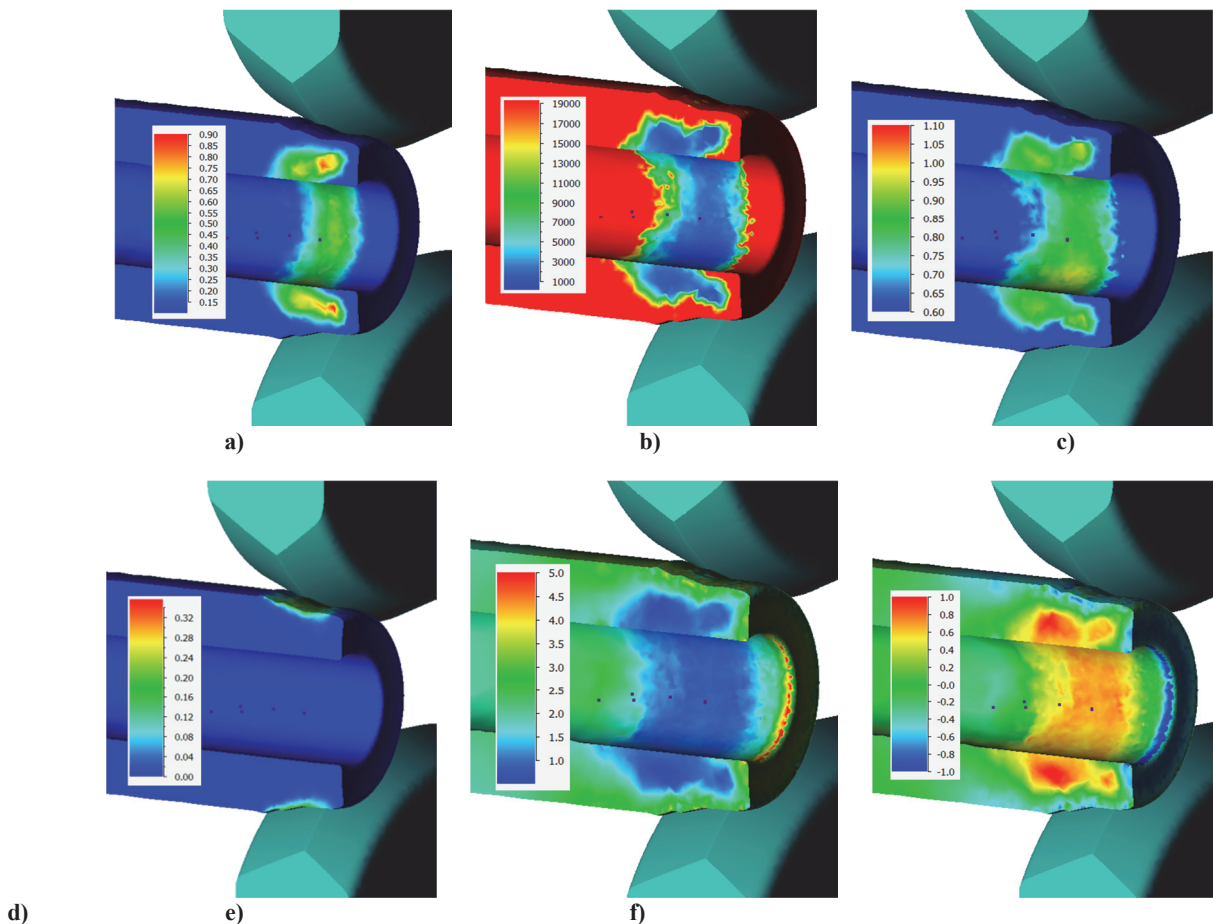

Fig. 16. Comparison of results of simulation for two described fracture models: values of fracture parameter D for criterion (16) (a), number of cycles to crack initiation (b), equivalent strain (in %) given by equation (15) (c), fracture parameter D for Kolmogorov fracture criterion (d), values of critical strains (e) and triaxiality factor (f).

ACKNOWLEDGMENTS

Financial assistance of the NCBR, project no. INNOLOT/1/7/NCBR/2013, is acknowledged.

This project was also supported in by PLGrid Infrastructure in ACK Cyfronet AGH.

REFERENCES

- Avitzur, B., 1968, Analysis of central bursting defects in extrusion and wire drawing, *Journal of Engineering for Industry*, 90, 79-90.
- Biba, N., Vlasov, A., Stebunov, S., Maximov, A., 2015, An approach to simulation of flow forming using elastic-visco-plastic material model, *13th International Cold Forming Congress*, Glasgow, 141-147.
- Depriester, D., Massoni, E., 2014, On the damage criteria and their critical values for flow forming of ELI grade Ti64, 2014, *Key Engineering Materials*, 622-623, 1221.
- Hensel, A., Spittel, T., 1979, Kraft- und Arbeitsbedarf Bildsamer Formgebungs-verfahren, *VEB Deutscher Verlag für Grundstoffindustrie*, Leipzig.
- Hua, F. A., Yang, Y. S., Zhang, Y. N., Guo, M. H., Guo, D. Y., Tong, W. H., Hu, Z. Q., 2005, Three-dimensional finite element analysis of tube spinning, *Journal of Materials Processing Technology*, 168, 68-74.
- Ierusalimsky, R., 2013, Programming in Lua, 3rd edition, Lua.org, Rio de Janeiro.
- Kolmogorov, V., 1986, Mechanika obrabotki metallow dawleniem, Metallurgy, Moscow.
- Kuss, M., Buchmayr, B., 2014, Radialschmieden versus Zylinderdrückwalzen, *BHM Berg- und Hüttenmännische Monatshefte*, 159, 208-213.
- Laflen, J. H., Cook, T. S., 1982, Equivalent damage - a critical assessment, General Electric Company, Lewis Research Center, Prepared for NASA, NASA-CR-167874 19830009271, 193.
- Mohebbi, M. S., Akbarzadeh, A., 2010, Experimental study and FEM analysis of redundant strains in flow forming of tubes, *Journal of Materials Processing Technology*, 210, 389-395.
- Stebunov, S., Biba, N., Vlasov, A., Maximov, A., 2011, Thermally and mechanically coupled simulation of metal forming processes, *10th International Conference on Technology of Plasticity ICTP*, Hirt, G., Tekkaya, A.E., Aachen, 171-175.
- Szeliga, D., Gawąd, J., Pietrzyk, M., 2006, Inverse analysis for identification of rheological and friction models in metal forming, *Computer Methods in Applied Mechanics and Engineering*, 195, 6778-6798.
- Wong, C. C., Dean, T. A., Lin, J., 2003, A review of spinning, shear forming and flow forming processes, *International Journal of Machine Tools & Manufacture*, 43, 1419-1435.



NUMERYCZNE PROGNOZOWANIE UTRATY SPÓJNOŚCI MATERIAŁU PODCZAS PRODUKCJI GRUBOŚCIENNYCH RUR Z NISKO PLASTYCZNYCH STALI ZA POMOCĄ PROCESU „FLOW FORMING”

Streszczenie

Proces walcowania poprzecznego w nienapędzanych rolkach (ang. flow forming) od dawna jest stosowany dla produkcji rur z nisko plastycznych stopów. W badaniach tego procesu szczególną uwagę zwraca się na odkształcalność (technologiczną plastyczność) materiału rury. W większości prac odkształcalność jest oceniana przez odpowiednie kryteria utraty spójności, które wykorzystują wyniki modelowania naprężeń i odkształceń metodą elementów skończonych (MES). Tymczasem podczas walcowania rur grubościennych wielokrotne cykliczne odkształcenie materiału rolkami powoduje powtórzenia procesów odkształcenia i odprężenia. W konsekwencji w materiale powstają i akumulują się naprężenia własne: ściskające na zewnętrznej powierzchni i rozciągające na wewnętrznej. Wartość tych naprężeń jest porównywalna z naprężeniami powstającymi podczas odkształcenia materiału rolkami. W pracy pokazano, że stosowanie do modelowania procesów „flow forming” programów MES z modelem materiału nie uwzględniającym odprężenia powoduje błędne przewidywanie nie tylko warunków utraty spójności, ale również lokalizacji powstawania pęknięć. W celu udowodnienia tej tezy opracowano dwa modele procesu walcowania rury grubościennej, które różniły się zastosowanym prawem konstytutywnym. Pierwszy model uwzględniał nie tylko sprężysto-plastyczne odkształcenie materiału, ale również procesy odprężenia. Drugi model był sztywno-plastyczny i nie uwzględniał odprężenia. W obu rozwiązaniach przyjęto taki sam model naprężenia uplastyczniającego, z początkowym odcinkiem opisującym sprężystość. Implementację modeli materiału oraz kilku kryteriów utraty spójności wykonano w środowisku programu Qform8. Porównanie wyników symulacji dla obu praw konstytutywnych wykazało, że w pierwszym przypadku powstają duże rozciągające naprężenia własne na wewnętrznej powierzchni rury, co podnosi ryzyko utraty spójności materiału w tych miejscach. Te naprężenia powstają nie tylko w strefie odkształcenia, ale wzdłuż całej rury. W drugim rozwiązaniu nie uwzględniającym odprężenia, maksymalne naprężenia powstają bezpośrednio w strefie odkształcenia. Rozkład parametrów kryteriów pęknięcia pokazuje różną lokalizację pęknięcia dla dwóch praw konstytutywnych. W pierwszym wariancie model przewiduje pęknięcie na wewnętrznej powierzchni rury, a w drugim wariancie na zewnętrznej. Z danych doświadczalnych wynika, że w analizowanych warunkach procesu pęknięcie rury powstaje na wewnętrznej powierzchni, na której wartości rozciągających rezydualnych naprężeń są największe. Potwierdza to konieczność uwzględnienia fazy odciążania materiału w symulacjach procesu dla rur grubościennych.

Received: November 12, 2015

Received in a revised form: February 24, 2016

Accepted: March 4, 2016

